



# Commercial Neptune<sup>®</sup> high-efficiency washers

*Our Fastest-Selling Washer!*



**SAVE UP TO  
50% OR MORE  
EVERY YEAR\***  
ON ENERGY, WATER AND  
SEWER COSTS.

Easy to program and simple to operate. In addition to eliminating hassles with coins, debit card systems greatly reduce the likelihood of machine vandalism. What's more, debit cards offer a wealth of opportunities for promotionally minded owners.

## Model MAH21PR

Maytag<sup>®</sup> Commercial Neptune<sup>®</sup> high-efficiency washers require substantially less water and energy than conventional washers to increase your profits and your bottom line. Yet, with no agitator, they hold substantially more laundry, including big and bulky items like bedspreads, blankets and throw rugs. High-speed extraction up to 1,000 rpm and 300 g's saves energy and reduces drying time to help dryers keep better pace with washers.

## debit card- ready

*Compatible with a variety of  
card systems for your convenience  
and greater flexibility!*

### For Your Customers:

- Eliminates coin hassles.
- Simple one-touch cycle selection.
- Display counts down time remaining in cycle.
- User-friendly Super Cycle provides option of three more minutes of wash time, extra rinse or both.
- Extra-large opening — door opens 180° for easy loading and unloading.
- Conveniently located three-compartment dispenser, which automatically dispenses detergent, softener and bleach.
- Meets ADA accessibility guidelines.

### For Your Operation:

- Simple soft-mount design for easy installation — no need to bolt the machine down.
- Easy-to-use service diagnostics.
- Reversible door provides installation flexibility.
- Optional audit system with two-way data communication.
- Allows owners to set vend prices in penny increments.

\*Based on testing with an 8-pound AHAM load with 15% hot-, 55% warm- and 30% cold-water wash at five turns per day and 365 days per year. Water, gas and sewer costs based on 2000 average U.S. national rates. Individual savings may vary.

*For more information, contact us at [www.maytagcommerciallaundry.com](http://www.maytagcommerciallaundry.com).*

# Model MAH21PR

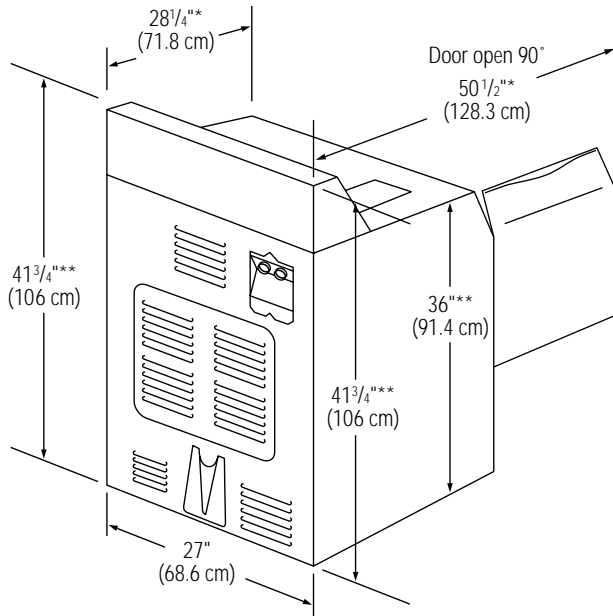

**Motor:** 120 volts, 50/60 Hz, variable speed, reversible, high-efficiency, switched reluctance motor. Develops 1/4 HP in wash and 1/2 HP in spin. Export models — 240 volts, 50 Hz.

**Capacity:** 2.9 cubic feet (0.08 cu. m).

**Inlet Hose Length:** 4 feet (1.22 m).

**Drain Hose Length:** 42 inches (109.7 cm).

**Approximate Water Usage:** 5.5 gallons (18.9 liters) hot-water cycle, 2 gallons (9.5 liters) warm-water cycle, approximately 15 gallons (56.7 liters) overall.<sup>1</sup>

**Electrical Rating:** 120 volts, 60 Hz. Export models — 240 volts, 50 Hz.

**Fuse Requirement:** 15 amp.

**Leveling Legs:** Adjustable to level washer for proper installation.

**Color:** White.

**Approximate Weight (Crated/Uncrated):**  
225 lbs. (102 kg) / 195 lbs. (88 kg).

\*Includes hinge on back of washer.

\*\*Dimensions will vary according to adjustment of leveling legs; add 2" min.

<sup>1</sup>Average based on testing with an 8-pound AHAM load. If optional additional rinse is used, add 5 gallons; not dependent on incoming pressure or time.



See specific instructions for proper installation.  
Specifications are subject to change without notice.

## Quality Features



### Big-Load Door Opening

Makes loading and unloading laundry a breeze. Extra-large stainless steel wash basket is designed to last a lifetime.

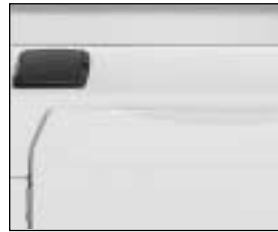

### Porcelain-Enamel Top

Provides a glass-smooth surface that resists scratches and laundry chemicals to keep your washer looking like new for years.



### Computer Trac® Controls

Simple to operate. The panel displays prices, instructions and more. Once the cycle begins, it counts down the remaining time.



### Precision Endurance Drive

Smooth and quiet. Drive adjusts to every installation and features an energy-saving switched reluctance motor.

## Maytag® Limited Warranty

2 YEARS — All parts

5 YEARS — Motor, wash basket, shaft assembly, bearings, seals and external cabinet against rust-through, including the shell, top, door and baseframe

For a period from the date of original purchase through the times listed above, the designated parts that fail in normal commercial use will be repaired or replaced free of charge for the part itself, with the owner paying all other costs, including labor, transportation and customs duty. Chemical damage is excluded from all warranty coverage. See complete warranty for details.

